

Design and realization of a 300 W fuel cell generator on an electric bicycle

Luciano Cardinali, Saverio Santomassimo, Marco Stefanoni*

ENEA, Italian Agency for New Technology, Energy and Environment, Advanced Energy Technologies Division,
Casaccia Research Center, Via Anguillarese, 301-S. M. di Galeria, 00060 Rome, Italy

Abstract

At ENEA Casaccia Research Center (Rome, Italy) a 300 W NUVERA fuel cell stack has been utilized for the construction of a range extender generator on a commercial electric bicycle.

The generator is fully automated with a programmable logic controller (PLC) safely operating start-up, shut-down and emergencies; a volumetric compressor supplies air to the cathode, a dc/dc converter transfers energy from the stack to the battery. All ancillary equipment are commercial; only the cell voltage sensors have been developed in order to obtain miniaturized and low consumption components.

With this generator the bicycle nominal range of 25 km (utilizing only the Ni-Mh battery) is extended to over 120 km, by installing a 200 bar, 5 l bottle of hydrogen. © 2002 Elsevier Science B.V. All rights reserved.

Keywords: Fuel cell vehicles; Hybrid system

1. Introduction

In 1989, ENEA started an R&D activity in co-operation with the Italian De Nora company for the development of proton exchange membrane fuel cells [1]; in the year 2000, De Nora Fuel Cells merged with EPYX to form Nuvera Inc.

A NUVERA 300 W stack has been used by ENEA for the construction of an easy-to-use, robust, safe power generating system installed on a commercial electric bicycle. The generator acts as a range extender of the electric bicycle.

Only commercially available components were chosen for the system, whenever possible; an ad hoc single cell voltage detection device was developed.

The system is not optimized in weight and dimension: it is only a first low cost prototype, useful to demonstrate the technology of fuel cells on bicycles and scooters and to obtain direct information on operating tests. With this prototype we want also to improve the public acceptance of the technology and to accelerate the national licensing processes in the field of interest (Fig. 1).

2. System design

A preliminary study of the system was carried out with the development of a simple simulation model by using an Excel

5.0 worksheet. A reduction of the balance-of-plant power consumption was reached by simplifying the electric, hydraulic and control circuits through a careful choice of low consumption components and by preferring mechanical regulation [2,3]. The conceptual process and instrument design (P&ID) of the system is shown in Fig. 2. Hydrogen is provided to the system by a pressurized bottle (5 l, 200 bar) and brought to the stack working pressure by a hand regulator (PC1). Along the feeding line a solenoid valve V1 turns the gas fuel off, during normal and emergency shut-downs; the exhaust line is equipped with valve V3 which operates a periodic purge from the anode. Along the air line two other solenoid valves (V2 and V4) are mounted to lock and inertize the cathode, in order to avoid damages to the stack during outages. The stack is air cooled with a temperature regulated variable speed fan (M1).

For the single cell voltage detection we develop a device made of 20 channels (one every two cells), two different thresholds per channel, with two 100 mm × 220 mm card and a power consumption as low as 5 W.

In Table 1, the main data of the NUVERA stack utilized are showed.

The power electric circuit consists in a buffer battery (25 V, 9 Ah), two dc/dc converters (2 × 150 W), an electric motor (230 W); the converters maintain the voltage of the battery to 26.1 V, varying the current in relation to the demand of the motor and of the state-of-charge of the battery; exclusion of the second converter is performed in order to reduce the load during start-up or to avoid too large

* Corresponding author. Tel.: +390-6-30483313;

fax: +390-6-30483190.

E-mail address: marco.stefanoni@casaccia.enea.it (M. Stefanoni).

Fig. 1. The H₂ bicycle.Table 1
Stack data

Model	NUVERA E. AN3
Nominal power	330 W
Nominal voltage	26.8 V
Nominal current	12.4 A
Fins operating temperature	40 °C
Number of cells	40
Stoichiometric cathodic ratio	2.3
Anodic inlet pressure	1.7 bar
Cathodic inlet pressure	1.2 bar

current battery charge. Utilizing this “hybrid series” configuration it is possible to avoid the over sizing of the generating system with respect to the peak requests of the electric motor, buffered by the battery.

The electric motor assists the bicycle user providing a torque proportional to that given on the pedals.

Table 2
System data

H ₂ inlet (N l/h)	212
Stack gross power (W)	333
Control system (W)	17
Solenoid valves (W)	10
Fans (W)	16
Compressor (W)	42
Efficiency dc/dc (%)	84
Net power (W)	194
System efficiency (on LHV) (%)	31.5
Range (km)	100–130

The main results of the simulation of the selected system configuration are reported in Table 2.

3. Control system

By using a Mitsubishi Alpha controller we were able to achieve a compact control system, with low power consumption and capable of the necessary automatic phases of the whole system; it performs the following functions:

Test: to detect leaks between cathode and anode.

Start-up: hydrogen and air tubing purge and cell voltage detection, in open circuit conditions.

Partial load: the stack is switched to supply half power.

Full load: after a short warming-up period, the stack is automatically switched to supply full power.

Stop: H₂ supply to be cut off, cell voltages to be lowered, gas lines to be drained, oxygen to be washed out from the cathode, all the auxiliary devices to be disconnected.

Emergency stop: in case of an alarm coming up, due to either low cell voltage, high stack temperature and high or low H₂ pressure, the controller breaks the H₂ off, stops all the auxiliary devices and lowers the stack voltage.

4. Experimental results

The generator underwent 50 h bench testing, showing stable performances.

By using the results of these tests a curve of efficiency versus load was obtained (Fig. 3), showing values over 31% in the range of 50–100% of the load.

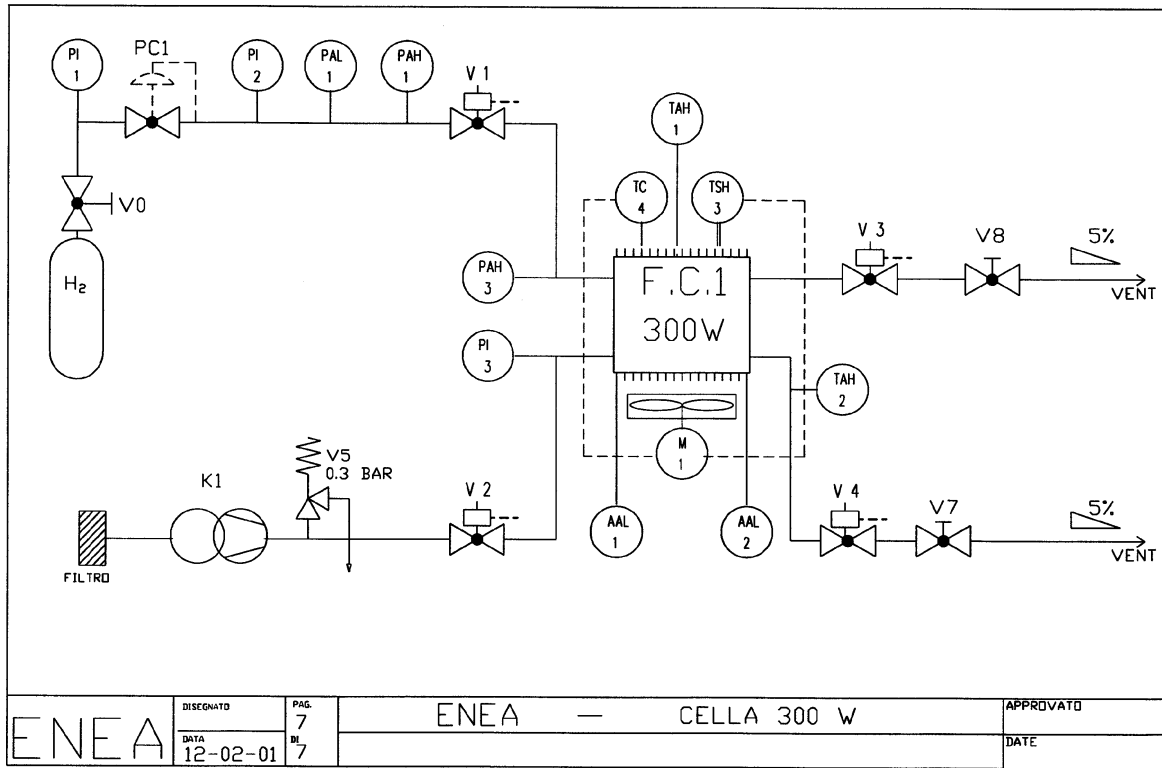

Fig. 2. PI&D.

The bicycle was also tested on a 3.7 km run inside the ENEA Research Center, characterized by 40 m of total slope and stop at seven crossings (Fig. 4). The average daily test length was 2.5 h, at a mean speed of 18 km/h. In this condition the range covered in a 3-day test with a bottle

of 1 N m³ of H₂ was of 120 km. The system showed constant and reliable operation without any failure; the battery maintained high his state-of-charge, acting also as a back-up storage for further 20 km in case of failure of the generator or emptying of the bottle.

System efficiency

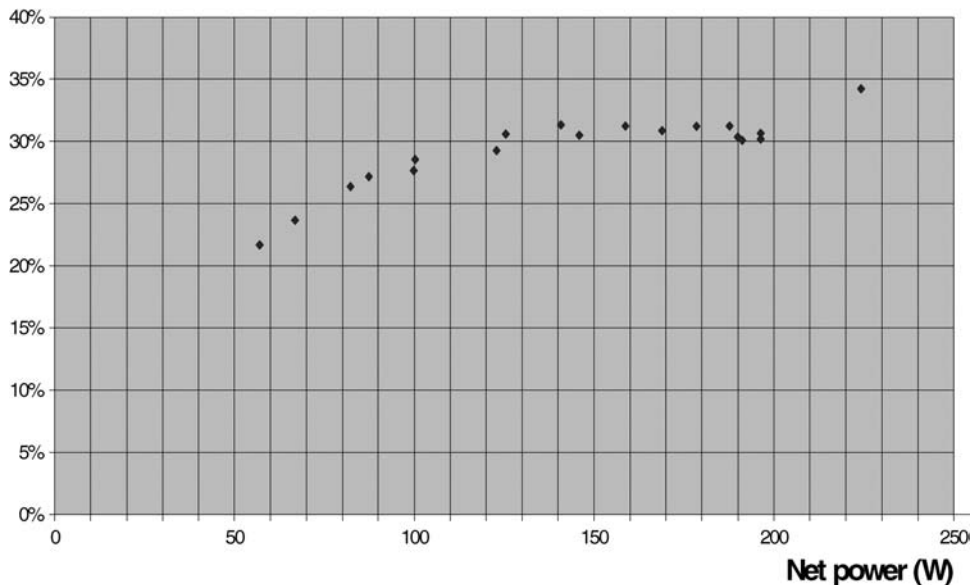

Fig. 3. System efficiency vs. net power.



Fig. 4. Bicycle during road test.

5. Conclusions

An electric bicycle supplied by a PEM stack generator based on Italian technology was designed, built and tested successfully.

The information gained with current experience will be useful in our labs for further developments on this technology. As future activity the system is going to be subject to endurance test for life assessment of both stack and components. The apparatus may be also useful for the improvement of the public acceptance of the hydrogen and to facilitate the licensing processes of this technology.

References

- [1] Prospettive per i veicoli elettrici con celle a combustibile, Raffaele Vellone, *ENERGIA* 3/98.
- [2] I. Popelis, A. Tsukada, G. Scherer, 12 V 300 W PEFC power pack, in: *Proceedings of the International Conference on Portable Fuel Cells*, Lucerne, Switzerland, 21–24 June 1999.
- [3] M. Brocco, S. Santomassimo, M. Stefanoni, A portable demonstration 12 V, 75 W fuel cell generator, in: *Proceedings of First European Polymer Electrolyte Fuel Cell Forum*, Lucerne, Switzerland, 2–6 July 2001.